

PAPER-III
ELECTRONIC SCIENCE

Signature and Name of Invigilator

1. (Signature) _____
(Name) _____
2. (Signature) _____
(Name) _____

- OMR Sheet No. :
(To be filled by the Candidate)
- Roll No.

--	--	--	--	--	--	--	--

(In figures as per admission card)
- Roll No. _____
(In words)

D 8 8 1 2

Time : 2 1/2 hours]

[Maximum Marks : 150

Number of Pages in this Booklet : 12

Number of Questions in this Booklet : 75

Instructions for the Candidates

- Write your roll number in the space provided on the top of this page.
- This paper consists of seventy five multiple-choice type of questions.
- At the commencement of examination, the question booklet will be given to you. In the first 5 minutes, you are requested to open the booklet and compulsorily examine it as below :
 - To have access to the Question Booklet, tear off the paper seal on the edge of this cover page. Do not accept a booklet without sticker-seal and do not accept an open booklet.
 - Tally the number of pages and number of questions in the booklet with the information printed on the cover page. Faulty booklets due to pages/questions missing or duplicate or not in serial order or any other discrepancy should be got replaced immediately by a correct booklet from the invigilator within the period of 5 minutes. Afterwards, neither the Question Booklet will be replaced nor any extra time will be given.**
 - After this verification is over, the OMR Sheet Number should be entered on this Test Booklet.
- Each item has four alternative responses marked (A), (B), (C) and (D). You have to darken the circle as indicated below on the correct response against each item.
Example : (A) (B) (C) (D)
where (C) is the correct response.
- Your responses to the items are to be indicated in the **OMR Sheet given inside the Booklet only**. If you mark at any place other than in the circle in the OMR Sheet, it will not be evaluated.
- Read instructions given inside carefully.
- Rough Work is to be done in the end of this booklet.
- If you write your Name, Roll Number, Phone Number or put any mark on any part of the OMR Sheet, except for the space allotted for the relevant entries, which may disclose your identity, or use abusive language or employ any other unfair means, you will render yourself liable to disqualification.
- You have to return the test question booklet and Original OMR Sheet to the invigilators at the end of the examination compulsorily and must not carry it with you outside the Examination Hall. You are, however, allowed to carry duplicate copy of OMR Sheet on conclusion of examination.
- Use only Blue/Black Ball point pen.
- Use of any calculator or log table etc., is prohibited.
- There is no negative marks for incorrect answers.

परीक्षार्थियों के लिए निर्देश

- पहले पृष्ठ के ऊपर नियत स्थान पर अपना रोल नम्बर लिखिए ।
- इस प्रश्न-पत्र में पचहत्तर बहुविकल्पीय प्रश्न हैं ।
- परीक्षा प्रारम्भ होने पर, प्रश्न-पुस्तिका आपको दे दी जायेगी । पहले पाँच मिनट आपको प्रश्न-पुस्तिका खोलने तथा उसकी निम्नलिखित जाँच के लिए दिये जायेंगे, जिसकी जाँच आपको अवश्य करनी है :
 - प्रश्न-पुस्तिका खोलने के लिए उसके कवर पेज पर लगी कागज की सील को फाड़ लें । खुली हुई या बिना स्टीकर-सील की पुस्तिका स्वीकार न करें ।
 - कवर पृष्ठ पर छपे निर्देशानुसार प्रश्न-पुस्तिका के पृष्ठ तथा प्रश्नों की संख्या को अच्छी तरह चेक कर लें कि ये पूरे हैं । दोषपूर्ण पुस्तिका जिनमें पृष्ठ/प्रश्न कम हों या दुबारा आ गये हों या सीरियल में न हों अर्थात् किसी भी प्रकार की त्रुटिपूर्ण पुस्तिका स्वीकार न करें तथा उसी समय उसे लौटाकर उसके स्थान पर दूसरी सही प्रश्न-पुस्तिका ले लें । इसके लिए आपको पाँच मिनट दिये जायेंगे । उसके बाद न तो आपकी प्रश्न-पुस्तिका वापस ली जायेगी और न ही आपको अतिरिक्त समय दिया जायेगा ।**
 - इस जाँच के बाद OMR पत्रक की क्रम संख्या इस प्रश्न-पुस्तिका पर अंकित कर दें ।
- प्रत्येक प्रश्न के लिए चार उत्तर विकल्प (A), (B), (C) तथा (D) दिये गये हैं । आपको सही उत्तर के वृत्त को पेन से भरकर काला करना है जैसा कि नीचे दिखाया गया है ।
उदाहरण : (A) (B) (C) (D)
जबकि (C) सही उत्तर है ।
- प्रश्नों के उत्तर केवल प्रश्न पुस्तिका के अन्दर दिये गये OMR पत्रक पर ही अंकित करने हैं । यदि आप OMR पत्रक पर दिये गये वृत्त के अलावा किसी अन्य स्थान पर उत्तर चिह्नांकित करते हैं, तो उसका मूल्यांकन नहीं होगा ।
- अन्दर दिये गये निर्देशों को ध्यानपूर्वक पढ़ें ।
- कच्चा काम (Rough Work) इस पुस्तिका के अन्तिम पृष्ठ पर करें ।
- यदि आप OMR पत्रक पर नियत स्थान के अलावा अपना नाम, रोल नम्बर, फोन नम्बर या कोई भी ऐसा चिह्न जिससे आपकी पहचान हो सके, अंकित करते हैं अथवा अभद्र भाषा का प्रयोग करते हैं, या कोई अन्य अनुचित साधन का प्रयोग करते हैं, तो परीक्षा के लिये अयोग्य घोषित किये जा सकते हैं ।
- आपको परीक्षा समाप्त होने पर प्रश्न-पुस्तिका एवं मूल OMR पत्रक निरीक्षक महोदय को लौटाना आवश्यक है और परीक्षा समाप्ति के बाद उसे अपने साथ परीक्षा भवन से बाहर न लेकर जायें । हालांकि आप परीक्षा समाप्ति पर OMR पत्रक की डुप्लीकेट प्रति अपने साथ ले जा सकते हैं ।
- केवल नीले/काले बाल प्वाइंट पेन का ही इस्तेमाल करें ।
- किसी भी प्रकार का संगणक (कैलकुलेटर) या लाग टेबल आदि का प्रयोग वर्जित है ।
- गलत उत्तरों के लिए कोई अंक काटे नहीं जाएँगे ।

**ELECTRONIC SCIENCE
PAPER – III**

Note : This paper contains **seventy five (75)** objective type questions of **two (2)** marks each.
All questions are compulsory.

1. An n-type silicon sample has a resistivity of $5 \Omega\text{-cm}$ at $T = 300 \text{ K}$. If mobility is $\mu_n = 1350 \text{ cm}^2/\text{V-s}$, then donor impurity concentration is
- (A) $2.86 \times 10^{-14} \text{ cm}^{-3}$
 (B) $9.25 \times 10^{14} \text{ cm}^{-3}$
 (C) $11.46 \times 10^{15} \text{ cm}^{-3}$
 (D) $1.1 \times 10^{-15} \text{ cm}^{-3}$

2. In a JFET, the amplification factor μ , transconductance g_m and the dynamic drain resistance v_d are related as
- (A) $\mu = \frac{g_m}{v_d}$ (B) $\mu = \frac{v_d}{g_m}$
 (C) $\mu = g_m \cdot v_d$ (D) $\mu = g_m \cdot v_d^2$

3. The figure shown below, is symbol of

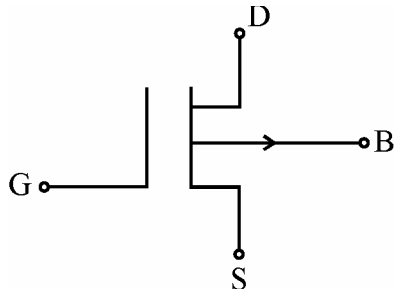

- (A) P – channel depletion MOSFET
 (B) P-channel enhancement MOSFET
 (C) Complementary MOSFET
 (D) P-channel JFET
4. If $Z_{11} = 2\Omega, Z_{12} = 1 \Omega, Z_{21} = 1 \Omega, Z_{22} = 3\Omega$
 What is the determinant of admittance matrix ?
- (A) 0 (B) 1
 (C) 5 (D) 1/5

5. If the branch in any network has a current source then the analysis is carried out by _____ analysis method.

(A) mesh (B) node
 (C) supermesh (D) supernode

6. The transfer function of RC low-pass filter network
- (A) $RCs/1 + RCs$ (B) $1/1 + RCs$
 (C) $RC/1 + RCs$ (D) $S/1 + RCs$

7. Biasing is done in class A mode to
- (A) save power
 (B) improve stability
 (C) reduce number of sources
 (D) both (B) and (C)

8. In analog computation, we use
- (A) both integrator and differentiator
 (B) only integrator
 (C) only differentiator
 (D) both in pair

9. To obtain 30% feedback factor for the circuit shown below :

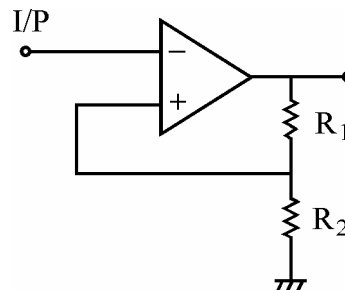

- (A) $R_1 = 3R_2$
 (B) $2R_1 = 5R_2$
 (C) $3R_1 = 7R_2$
 (D) $5R_1 = 9R_2$

10. For $I_{OLmax} = 16 \text{ mA}$ and $I_{ILmax} = 0.0016 \text{ A}$, the fan-out (low) is
 (A) 16 (B) 10
 (C) 1 (D) 1.6

11. Which Boolean expression describes the output 'X' in the arrangement given below :

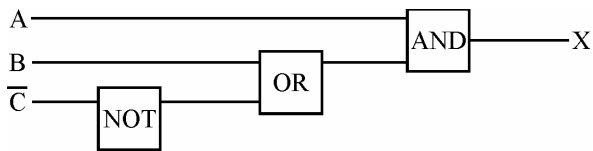

- (A) $X = a + (b \cdot c)$
 (B) $X = a \cdot (b + c)$
 (C) $X = (a \cdot b) + c$
 (D) $X = a + b + c$
12. The largest decimal number that can be stored in a MOD-64 counter is
 (A) 64 (B) 15
 (C) 16 (D) 63
13. What is the Register address which matches with the address of the stack ?
 (A) 03H (B) 07H
 (C) 013H (D) 13H
14. In 8259, to avoid causing an interrupt due to an accidental noise pulse, the following action is done :
 (A) All unused interrupt lines are shorted together.
 (B) All unused interrupt lines are connected to V_{cc} .
 (C) All unused interrupt lines are connected to ground.
 (D) All unused interrupt lines kept open.

15. Which of the ports in 8255, in which part of the port pins can be used as input lines and part of the port pins can be used as output lines ?
 (A) PA (B) PB
 (C) PC (D) PD

16. Which loop structure would execute its statements atleast once even if the test condition fails for the first time itself ?
 (A) for (B) if-else
 (C) do-while (D) while

17. The expression evaluates to false in
 $\text{int } l = 3, J = 7;$
 $\text{double } f = 5.5, g = 4.5;$
 $\text{char } ch = 'T';$
 (A) $(l <= 5) \&\& (ch == 'T')$
 (B) $(l < 8) \&\& (ch == 'L')$
 (C) $(f >= 6) \&\& (l \cdot j) < 15$
 (D) $(f + g) == 10.011 \text{ i } < 2$

18. Word NEHA is to be entered in an array. Which array declaration is proper ?
 (A) $\text{Char name } [4] = \{ 'N', 'E', 'H', 'A' \};$
 (B) $\text{Char name } [5] = \{ 'N', 'E', 'H', 'A', '\backslash 0' \};$
 (C) $\text{Char name } [4] = \text{"NEHA"};$
 (D) $\text{Char name } [4] = \text{'NEHA'};$

19. A transmission line having 50Ω impedance is transmitted to a load of $(40 + j 30)$ ohms. The VSWR is
 (A) $j 0.033$ (B) $0.8 + j 0.6$
 (C) 2 (D) 1

20. An air filled rectangular waveguide has dimensions $6 \text{ cm} \times 4 \text{ cm}$. The cut off frequency for TE_{10} is
 (A) 2.5 GHz (B) 25 MHz
 (C) 20.5 GHz (D) 5 GHz

21. An antenna, when radiating, has a highly directional radiation pattern. When the antenna is receiving, its radiation pattern
- is more directive
 - is less directive
 - is same that of transmitting antenna
 - exhibits no directivity at all.
22. The modulation index of an AM wave in changed from 0 to 1. The transmitted power is
- unchanged
 - halved
 - doubled
 - increased by 50 percent
23. In a low level AM system, amplifiers following the modulated stage must be
- Linear devices
 - Harmonic devices
 - Class C amplifier
 - Non linear devices
24. Indicate the false statement. The square of the thermal noise voltage generated by a resistor is proportional to
- its temperature
 - its resistance
 - Boltzmann constant
 - the bandwidth over which it is measured
25. The output of a dc motor depends mainly on
- Speed and torque
 - Speed and back emf
 - Speed and applied voltage
 - Speed and load resistance
26. Which one of the following is an adjustable IC voltage regulator ?
- IC 7824
 - IC 7912
 - LM 338
 - IC 7808
27. The attenuation of a single mode fibers is 0.2 dB/km, at a transmission length of 100 kms. The output signal strength is reduced to
- 10% of transmitted power
 - 1% of transmitter power
 - 5% of the transmitted power
 - 20% of the transmitted power
28. A Resistance strain gauge has gauge factor of 2. It is connected to a steel member which is subjected to a strain of 1×10^{-6} . If the original resistance value of the gauge is 130Ω , what is the change in resistance ?
- $130 \mu\Omega$
 - $390 \mu\Omega$
 - $260 \mu\Omega$
 - $520 \mu\Omega$
29. What will be the output of K-type thermocouple at 100°C ?
- $40 \mu\text{V}$
 - $400 \mu\text{V}$
 - $4000 \mu\text{V}$
 - 4 V
30. A system is said to be stable if and only if
- All poles lie on the right half of S. plane.
 - All poles lie in the left half of the S-plane.
 - All poles and zeros lie on the right half of S-planes.
 - Some poles lie on the half of the S-plane and some lie on the right half of the S-plane.
31. Which of the following is/are valid statement(s) ?
- AJFET has one built-in diode.
 - AJFET has two built-in diode.
 - The pinch off voltage of a JFET has same magnitude as that of gate voltage.
 - A JFET is a voltage controlled device.
- I, III, IV
 - II, III, IV
 - II, III
 - II, IV

32. Is it necessary to separately define Z and Y parameters as Z can be obtained from Y and vice a versa ?

- I. Not necessary to define Y and Z separately as $Y = 1/Z$.
 - II. Necessary as Z-parameters cannot be defined at high frequency.
 - III. $Y = 1/Z$ is applicable only at low frequency, so conversion is not valid under all conditions.
 - IV. Hybrid π -model enables Z to be determined using $Z = 1/Y$.
- (A) Options I and III are correct.
 (B) Options II and IV are correct.
 (C) Options III and IV are correct.
 (D) Options IV and I are correct.

33. Which of the following three pin regulators yield +9 V output ?

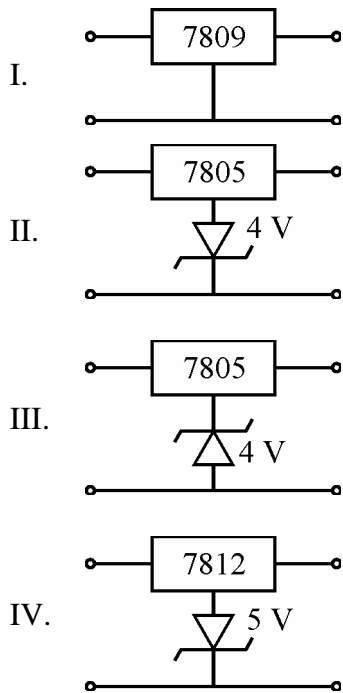

- (A) Options I and III are correct.
 (B) Options II and IV are correct.
 (C) Options III and II are correct.
 (D) Options IV and I are correct.

34. Which of the following circuit come under the class of combinational logic circuits ?

- I. Full Adder
 - II. Full Subtractor
 - III. Counter
 - IV. Multiplexer
- (A) I and II are correct.
 (B) I, II, IV are correct.
 (C) II, III, IV are correct.
 (D) I, III and IV are correct.

35. For using 8253 in counter mode from a initial value.

- I. The control word for selection of counter is done.
 - II. The initial value will be kept in the counter before the selection of counter.
 - III. Selection of BCD mode is done.
 - IV. The initial value will be loaded to counter after the selection of counter.
- (A) I, III and IV are to be fulfilled.
 (B) I, II and III are to be fulfilled.
 (C) II, III and IV are to be fulfilled.
 (D) II, I and IV are to be fulfilled.

36. Which of the following statements will post increment the variable by 1 ?

- I. $a = a + 1;$
 - II. $a += 1;$
 - III. $a ++;$
 - IV. $a = + 1;$
- (A) Options I, II, III are correct.
 (B) Options II, III, IV are correct.
 (C) Options I, II are correct.
 (D) Options III, IV are correct.

37. In optical fiber communications
- I. Inter modal dispersion can be avoided by using SMF.
 - II. Inter modal dispersion can be avoided by using MMF.
 - III. Third transmission window wavelength is used to avoid Rayleigh scattering losses.
 - IV. 800-900 nm window is used to avoid Rayleigh's scattering losses.
- (A) Options II and III are correct.
 - (B) Options II and IV are correct.
 - (C) Options I and III are correct.
 - (D) Options IV and I are correct.
38. Indicate the false statement.
- (i) HF mixers are generally noisier than HF amplifier.
 - (ii) Impulse noise voltage is independent of bandwidth.
 - (iii) In thermal noise, the noise power generated by a resistor, is proportional to the bandwidth.
 - (iv) Industrial noise is not an impulse type.
- (A) (i) and (ii) are correct.
 - (B) (ii) and (iii) are correct.
 - (C) (iii) and (iv) are correct.
 - (D) (i) and (iii) are correct.
39. For a loss-less transmission line with air as dielectric operating at 15 MHz and of length = 12 m.
- I. The length of transmission line in terms of $\lambda = 0.6 \lambda$.
 - II. The value of phase constant is 0.1π radian/m.
 - III. The value of phase constant is 0.2π radian/m.
 - IV. The length of transmission line in terms of λ is $\lambda/4$.
- (A) Options I and II are correct.
 - (B) Options III and IV are correct.
 - (C) Options I and IV are correct.
 - (D) Options II and IV are correct.

40. During the process of milk boiling, the heater is to be put off before the bubble gets over spilled. The following controls are put in operation while switching off the heater. They are
- I. Only proportional
 - II. Only integral
 - III. proportional and derivative controls are followed.
 - IV. Only derivative
- (A) I as well as II are followed.
 - (B) I as well as IV are followed.
 - (C) Only III is followed.
 - (D) I, II and IV are followed.

Q. Nos. 41 to 50 :

Assertion – Reason type questions :

The following items consist of two statements, one labelled the 'Assertion (A)' and the other labelled the 'Reason (R)'. You are to examine these two statements and decide if the Assertion (A) and the Reason (R) are individually true and if so, whether the Reason is a correct explanation of the Assertion. Select your answers to these items using the codes given below and mark your answer sheet accordingly.

Codes :

- (A) Both (A) and (R) are true and (R) is the correct explanation of (A).
 - (B) Both (A) and (R) are true but (R) is not the correct explanation of (A).
 - (C) (A) is true and (R) is false.
 - (D) (A) is false and (R) is true.
41. **Assertion (A) :** An intrinsic semiconductor is doped lightly with p-type impurity. Its conductivity decreases till a certain doping level is reached.
- Reason (R) :** The mobility of both holes and electrons decreases.

42. **Assertion (A)** : Number of mesh current equations in a network depend upon the number of branches B and nodes N in a network.
Reason (R) : Number of mesh current equations are $B + N - 1$.
43. **Assertion (A)** : Offsets in op-amp are introduced due to mismatch at differential input stage. The offsets change with time and temperature.
Reason (R) : The offsets must be removed as they introduce noise in a.c. signals.
44. **Assertion (A)** : Dual slope A/D converter is the most preferred A/D conversion technique employed in most digital multimeters.
Reason (R) : Dual slope A/D converter provides high accuracy and also suppresses the HUM effect on the input signal.
45. **Assertion (A)** : The default address, for starting the execution of the program, is from 0000H. This is valid for Intel processors.
Reason (R) : The starting address of RAM is from 0000H.
46. **Assertion (A)** : The break; statement is used to exit from if statement.
Reason (R) : In while (1) loop break; statement is put at the end of a loop.
47. **Assertion (A)** : Magic Tee is a 4-junction hybrid Tee and displays power dividing properties in E and H plane and has advantage of being fully matched.
Reason (R) : It has a hybrid junction about an imaginary plane bisecting two arms.

48. **Assertion (A)** : In the super heterodyne receiver, the signal voltage is combined with local oscillator voltage and normally converted into a signal of a lower fixed frequency.
Reason (R) : The intermediate frequency of receiving system may be neither low or high, but in a certain range between the two.
49. **Assertion (A)** : PIN diodes are used as photo detectors. This is achieved by doping lightly doped in material in between p and n junctions.
Reason (R) : These are used because higher frequency infra-red penetrate more deeply in the semiconductor material.
50. **Assertion (A)** : Due to two metal with different coefficient of expansion, when the junction is formed, the junction produces a voltage corresponding to temperature.
Reason (R) : The metals which are used for making thermocouples are non homogeneous.
51. Arrange the following configurations of BJT in the increasing order of their input impedance.
I. CE II. CB
III. CC IV. Darlington pair
(A) III, II, IV, I (B) I, II, III, IV
(C) IV, III, II, I (D) II, I, III, IV
52. The sequence to the venise a network and calculate current through the load is
(i) obtain V_{TH} or R_{TH}
(ii) remove the load
(iii) put V_{TH} and R_{TH} in series
(iv) connect the load in series
The correct sequence is
(A) (i), (ii), (iii), (iv)
(B) (ii), (i), (iii), (iv)
(C) (iii), (i), (iv), (ii)
(D) (iv), (iii), (i), (ii)

53. The correct order in which data is most reliably transmitted

- (i) Current loop
- (ii) V to F conversion
- (iii) Voltage transmission
- (iv) Digital data communication

- (A) (iii), (i), (ii), (iv)
- (B) (ii), (iv), (i), (iii)
- (C) (i), (iv), (iii), (ii)
- (D) (iv), (iii), (ii), (i)

54. Consider the Analog to Digital conversion given below :

- I. Successive approximation ADC
- II. Dual-slope ADC
- III. Counter method ADC
- IV. Simultaneous ADC

The correct sequence of the ascending order in terms of speed of the above ADC's are :

- (A) I, II, III, IV
- (B) II, I, III, IV
- (C) IV, II, I, III
- (D) III, II, I, IV

55. The following operations are done during the execution of an instruction :

- (i) Decode
- (ii) Fetch
- (iii) Signal transfer
- (iv) Execute

- (A) (i), (ii), (iii), (iv)
- (B) (ii), (i), (iv), (iii)
- (C) (iii), (i), (ii), (iv)
- (D) (ii), (i), (iii), (iv)

56. The correct sequence of hierarchy of operators is _____. from highest to lowest.

- (i) - or +
- (ii) ()
- (iii) / or *
- (iv) * *

- (A) (i), (iii), (iv)
- (B) (ii), (iv), (iii)
- (C) (ii), (iii), (i)
- (D) (iv), (ii), (i)

57. Following are the mediums of communication :

- (i) sea water
- (ii) sky waves
- (iii) space waves
- (iv) glass fibers

The correct sequence of operating frequencies in increasing order are :

- (A) (iv), (iii), (ii), (i)
- (B) (i), (ii), (iii), (iv)
- (C) (ii), (iii), (iv), (i)
- (D) (iv), (ii), (iii), (i)

58. Following are the steps for A to D conversion of the signal :

- (i) Quantization
- (ii) Sampling
- (iii) Filtering
- (iv) Encoding

The correct sequence of A to D conversion is

- (A) (i), (ii), (iii), (iv)
- (B) (ii), (i), (iv), (iii)
- (C) (iv), (iii), (ii), (i)
- (D) (iii), (ii), (i), (iv)

59. Following are the detectors used in optical communication :

- (i) Photo diode
- (ii) Photo-transistor
- (iii) Avalanche photodiode
- (iv) Pin diode

Correct sequence of gain in decreasing order is given by

- (A) (iii), (iv), (ii), (i)
- (B) (iv), (iii), (ii), (i)
- (C) (i), (ii), (iii), (iv)
- (D) (iv), (ii), (iii), (i)

60. The correct sequence to be followed to build data acquisition system is by arranging the steps as follows :

- (i) transducer
- (ii) software development
- (iii) range of parameter
- (iv) signal conditioning
- (A) (i), (ii), (iii), (iv)
- (B) (iv), (iii), (ii), (i)
- (C) (iii), (i), (iv), (ii)
- (D) (ii), (iii), (iv), (i)

61. Match List – I with List – II.

List – I	List – II
a. Monostable multivibrator	1. No-stable state
b. Astable multivibrator	2. One-stable state
c. Free-running multivibrator	3. Two-stable state
d. Bistable multivibrator	4. Alternate high and low output

Codes :

	a	b	c	d
(A)	2	3	1	4
(B)	3	2	4	1
(C)	1	3	4	2
(D)	2	1	4	3

62. Match List – I with List – II and select the correct answer using codes given below :

List – I	List – II
a. Cut set	1. KVL
b. RC-differentiator	2. Branch voltage
c. Dual of KCL	3. Frequency response
d. Bode plots	4. High pass filter

Codes :

	a	b	c	d
(A)	2	4	1	3
(B)	3	2	4	1
(C)	4	3	1	2
(D)	1	2	4	3

63. Match List – I with List – II and select the correct answer using codes given below :

List – I	List – II
a. Duty cycle	1. Variable voltage regulator
b. AGC	2. Astable multivibrator
c. LM317	3. Voltage regulator
d. Crow-bar protection	4. FET

Codes :

	a	b	c	d
(A)	1	2	3	4
(B)	3	4	1	2
(C)	4	3	2	1
(D)	2	4	1	3

64. Match List – I with List – II and select the correct answer by using the codes given below the lists :

List – I	List – II
a. Multiplexer	1. Sequential memory
b. De-multiplexer	2. Converts decimal number to binary
c. Shift-register	3. Data Selection
d. Encoder	4. Routes out many data input with single data output

Codes :

	a	b	c	d
(A)	3	4	1	2
(B)	4	3	1	2
(C)	3	4	2	1
(D)	1	2	3	4

65. Match the following lists with correct ones :

- | List – I | | List – II | |
|------------|--|-----------------------------|--|
| a. QUE | | 1. Z flag not affected | |
| b. DX | | 2. Slow memory | |
| c. DCX D | | 3. Reg B | |
| d. MUL/DIV | | 4. Variable port addressing | |

Codes :

- | | a | b | c | d |
|-----|---|---|---|---|
| (A) | 4 | 2 | 3 | 1 |
| (B) | 2 | 4 | 3 | 1 |
| (C) | 4 | 2 | 1 | 3 |
| (D) | 2 | 4 | 1 | 3 |

66. Match List – I with List – II and select the correct answer using codes given below :

- | List – I | | List – II | |
|------------|--|--------------------------------|--|
| a. if-then | | 1. hex-data | |
| b. % x | | 2. garbage to calling function | |
| c. gets() | | 3. on-off controller | |
| d. return; | | 4. multi word string | |

Codes :

- | | a | b | c | d |
|-----|---|---|---|---|
| (A) | 3 | 1 | 4 | 2 |
| (B) | 2 | 3 | 4 | 1 |
| (C) | 1 | 2 | 3 | 4 |
| (D) | 4 | 3 | 2 | 1 |

67. Match List – I with List – II and select the correct answer using the codes given below :

- | List – I | | List – II | |
|-----------------------------|--|---|--|
| a. Wave equation | | 1. $\nabla \times \vec{H} = \vec{J} + \frac{\partial \vec{D}}{\partial t}$ | |
| b. $\vec{E} \times \vec{H}$ | | 2. $\nabla \cdot \vec{D} = \rho$ | |
| c. Gauss's Law | | 3. Poynting vector | |
| d. Ampere's Law | | 4. $\frac{1}{C^2} \frac{\partial^2 \vec{E}}{\partial t^2} = \nabla^2 \vec{E}$ | |

Codes :

- | | a | b | c | d |
|-----|---|---|---|---|
| (A) | 4 | 3 | 2 | 1 |
| (B) | 3 | 4 | 2 | 1 |
| (C) | 1 | 2 | 3 | 4 |
| (D) | 4 | 2 | 3 | 1 |

68. Match the following :

- | List – A | | List – B | |
|----------|--|---------------------------|--|
| a. Modem | | 1. Noise immunity better | |
| b. FSK | | 2. error correction | |
| c. Codes | | 3. frequency shift keying | |
| d. PCM | | 4. signal translator | |

Codes :

- | | a | b | c | d |
|-----|---|---|---|---|
| (A) | 4 | 3 | 2 | 1 |
| (B) | 3 | 2 | 1 | 4 |
| (C) | 2 | 1 | 3 | 4 |
| (D) | 1 | 4 | 2 | 3 |

69. Match List – I with List – II and select the correct answer using the codes given below :

- | List – I | | List – II | |
|-------------|--|---------------------------------|--|
| a. Choppers | | 1. pn pn devices | |
| b. SCR | | 2. V number | |
| c. SMF | | 3. Speed control of d.c. motors | |
| d. LASER | | 4. Quantum well | |

Codes :

- | | a | b | c | d |
|-----|---|---|---|---|
| (A) | 3 | 2 | 4 | 1 |
| (B) | 3 | 1 | 2 | 4 |
| (C) | 4 | 2 | 1 | 3 |
| (D) | 4 | 3 | 2 | 1 |

70. Match the following :

- | List – I | | List – II | |
|-------------------------|--|-----------------------|--|
| a. $3\frac{1}{2}$ digit | | 1. Guarding/shielding | |
| b. $P_t - 100$ | | 2. Bridge | |
| c. RTD | | 3. Temperature | |
| d. Interference | | 4. DVM | |

Codes :

- | | a | b | c | d |
|-----|---|---|---|---|
| (A) | 1 | 2 | 3 | 4 |
| (B) | 4 | 3 | 2 | 1 |
| (C) | 3 | 1 | 4 | 2 |
| (D) | 3 | 4 | 1 | 2 |

The World's first microprocessor, 4004, was introduced by Intel in 1968. It was a 4 bit processor, but later it has introduced a new processor almost every year, like 8080, 8085, 8086, 8031 and 8051. Only 8086 processor handles 16 bit data and a micro computer was developed based on this processor. Intel also introduced 80186, 80286, 80386, 80486 and made possible to get mini computers and personal computers.

Other companies like Texas instruments, Motorola, Zilog and Analog devices have specialized in signal processing processors, communication oriented processors, better architectural processor, and discrete signal processing devices.

All the advancements mentioned above are made possible because of continuous upgradation of VLSI technology. Some of the features like cache, pipelining and branch prediction have contributed for improving performance parameters, like execution speed, large memory, fast data transfers and reduction in number of instructions. A transformation has been seen from CISC to RISC.

Identification of application and its potential for marketing provides the opportunity to companies to produce ASICs sometimes. Digital Signal Processors are employed for processing streamed data of either voice or video data.

71. Expansion of ASIC is :
 - (A) Applied Science Integrated Circuit.
 - (B) Application Specific Integrated Circuit.
 - (C) Application Specific Internal Circuit.
 - (D) Application of Science and Integrated Circuit.

72. 8 bit data lines is not employed by the following processor :
 - (A) 8080
 - (B) 8085
 - (C) 8086
 - (D) 8051

73. Which one is not enhanced feature inspite of VLSI advances ?
 - (A) Pipelining
 - (B) Branch prediction
 - (C) Power consumption
 - (D) Cache

74. Which of the following is not signal processing ?
 - (A) Data filtering
 - (B) Convolution
 - (C) Noise addition
 - (D) Data storing

75. Expansion of RISC :
 - (A) Reduced Integrated Systems Circuit
 - (B) Reduced Instructions Set Computer
 - (C) Reduction Integrated System Computer
 - (D) Reduced Instructions System Circuit

Space For Rough Work