

PAPER-III
ELECTRONIC SCIENCE

Signature and Name of Invigilator

1. (Signature) _____
(Name) _____
2. (Signature) _____
(Name) _____

OMR Sheet No. :
(To be filled by the Candidate)

Roll No.

--	--	--	--	--	--	--	--

(In figures as per admission card)

Roll No. _____
(In words)

D 8 8 1 3

Time : 2 ½ hours]

[Maximum Marks : 150

Number of Pages in this Booklet : 12

Number of Questions in this Booklet : 75

Instructions for the Candidates

1. Write your roll number in the space provided on the top of this page.
2. This paper consists of seventy five multiple-choice type of questions.
3. At the commencement of examination, the question booklet will be given to you. In the first 5 minutes, you are requested to open the booklet and compulsorily examine it as below :
 - (i) To have access to the Question Booklet, tear off the paper seal on the edge of this cover page. Do not accept a booklet without sticker-seal and do not accept an open booklet.
 - (ii) **Tally the number of pages and number of questions in the booklet with the information printed on the cover page. Faulty booklets due to pages/questions missing or duplicate or not in serial order or any other discrepancy should be got replaced immediately by a correct booklet from the invigilator within the period of 5 minutes. Afterwards, neither the Question Booklet will be replaced nor any extra time will be given.**
 - (iii) After this verification is over, the OMR Sheet Number should be entered on this Test Booklet.
4. Each item has four alternative responses marked (A), (B), (C) and (D). You have to darken the circle as indicated below on the correct response against each item.
Example : (A) (B) (C) (D)
where (C) is the correct response.
5. Your responses to the items are to be indicated in the **OMR Sheet given inside the Booklet only**. If you mark at any place other than in the circle in the OMR Sheet, it will not be evaluated.
6. Read instructions given inside carefully.
7. Rough Work is to be done in the end of this booklet.
8. If you write your Name, Roll Number, Phone Number or put any mark on any part of the OMR Sheet, except for the space allotted for the relevant entries, which may disclose your identity, or use abusive language or employ any other unfair means such as change of response by scratching or using white fluid, you will render yourself liable to disqualification.
9. You have to return the test question booklet and Original OMR Sheet to the invigilators at the end of the examination compulsorily and must not carry it with you outside the Examination Hall. You are, however, allowed to carry duplicate copy of OMR Sheet on conclusion of examination.
10. Use only **Blue/Black Ball point pen**.
11. Use of any calculator or log table etc., is prohibited.
12. There is no negative marks for incorrect answers.

परीक्षार्थियों के लिए निर्देश

1. इस पृष्ठ के ऊपर नियत स्थान पर अपना रोल नम्बर लिखिए ।
2. इस प्रश्न-पत्र में पचहत्तर बहुविकल्पीय प्रश्न हैं ।
3. परीक्षा प्रारम्भ होने पर, प्रश्न-पुस्तिका आपको दे दी जायेगी । पहले पाँच मिनट आपको प्रश्न-पुस्तिका खोलने तथा उसकी निम्नलिखित जाँच के लिए दिये जायेंगे, जिसकी जाँच आपको अवश्य करनी है :
 - (i) प्रश्न-पुस्तिका खोलने के लिए उसके कवर पेज पर लगी कागज की सील को फाड़ लें । खुली हुई या बिना स्टीकर-सील की पुस्तिका स्वीकार न करें ।
 - (ii) **कवर पृष्ठ पर छपे निर्देशानुसार प्रश्न-पुस्तिका के पृष्ठ तथा प्रश्नों की संख्या को अच्छी तरह चैक कर लें कि ये पूरे हैं । दोषपूर्ण पुस्तिका जिनमें पृष्ठ/प्रश्न कम हों या दुबारा आ गये हों या सीरियल में न हों अर्थात् किसी भी प्रकार की त्रुटिपूर्ण पुस्तिका स्वीकार न करें तथा उसी समय उसे लौटाकर उसके स्थान पर दूसरी सही प्रश्न-पुस्तिका ले लें । इसके लिए आपको पाँच मिनट दिये जायेंगे । उसके बाद न तो आपकी प्रश्न-पुस्तिका वापस ली जायेगी और न ही आपको अतिरिक्त समय दिया जायेगा ।**
 - (iii) इस जाँच के बाद OMR पत्रक की क्रम संख्या इस प्रश्न-पुस्तिका पर अंकित कर दें ।
4. प्रत्येक प्रश्न के लिए चार उत्तर विकल्प (A), (B), (C) तथा (D) दिये गये हैं । आपको सही उत्तर के वृत्त को पेन से भरकर काला करना है जैसा कि नीचे दिखाया गया है ।
उदाहरण : (A) (B) (C) (D)
जबकि (C) सही उत्तर है ।
5. प्रश्नों के उत्तर केवल प्रश्न पुस्तिका के अन्दर दिये गये OMR पत्रक पर ही अंकित करने हैं । यदि आप OMR पत्रक पर दिये गये वृत्त के अलावा किसी अन्य स्थान पर उत्तर चिह्नित करते हैं, तो उसका मूल्यांकन नहीं होगा ।
6. अन्दर दिये गये निर्देशों को ध्यानपूर्वक पढ़ें ।
7. कच्चा काम (Rough Work) इस पुस्तिका के अन्तिम पृष्ठ पर करें ।
8. यदि आप OMR पत्रक पर नियत स्थान के अलावा अपना नाम, रोल नम्बर, फोन नम्बर या कोई भी ऐसा चिह्न जिससे आपकी पहचान हो सके, अंकित करते हैं अथवा अभद्र भाषा का प्रयोग करते हैं, या कोई अन्य अनुचित साधन का प्रयोग करते हैं, जैसे कि अंकित किये गये उत्तर को मिटाना या सफेद स्याही से बदलना तो परीक्षा के लिये अयोग्य घोषित किये जा सकते हैं ।
9. आपको परीक्षा समाप्त होने पर प्रश्न-पुस्तिका एवं मूल OMR पत्रक निरीक्षक महोदय को लौटाना आवश्यक है और परीक्षा समाप्त के बाद उसे अपने साथ परीक्षा भवन से बाहर न लेकर जायें । हालांकि आप परीक्षा समाप्त पर OMR पत्रक की डुप्लीकेट प्रति अपने साथ ले जा सकते हैं ।
10. केवल नीले/काले बाल प्वाइंट पेन का ही इस्तेमाल करें ।
11. किसी भी प्रकार का संगणक (कैलकुलेटर) या लाग टेबल आदि का प्रयोग वर्जित है ।
12. गलत उत्तरों के लिए कोई नकारात्मक अंक नहीं है ।

ELECTRONIC SCIENCE
Paper – III

Note : This paper contains **seventy five (75)** objective type questions of **two (2)** marks each.
All questions are compulsory.

1. In an npn transistor, the expression for avalanche multiplication factor is given by

(A) $M = \frac{1}{(1 + V_{CB}/B V_{CBO})^n}$
 (B) $M = (1 + V_{CB}/B V_{CBO})^n$
 (C) $M = (1 - V_{CB}/B V_{CBO})^n$
 (D) $M = \frac{1}{[1 - (V_{CB}/B V_{CBO})^n]}$

Where, V_{CB} is collector to base voltage and BV_{CBO} is maximum reverse biasing voltage which may be applied before breakdown between the collector and base terminals.

2. In a bipolar transistor, stability factor for a fixed bias circuit is given by

(A) $S = \frac{1}{1 + \beta}$ (B) $S = \frac{1}{\beta - 1}$
 (C) $S = (\beta - 1)^2$ (D) $S = \beta + 1$

3. In a Wein bridge oscillator circuit, the value of frequency can be calculated by the following expression :

(A) $f_o = \frac{1}{2\pi RC}$
 (B) $f_o = \frac{1}{2\pi \sqrt{LC}}$
 (C) $f_o = \frac{1}{2\pi \sqrt{L_1(C_1 + C_2)}}$
 (D) $f_o = \frac{1}{2\pi \sqrt{(R_1^2 + R_2^2)(C_1^2 + C_2^2)}}$

4. The value of magnetic field density is given by expression $\vec{H} = 28 \sin x \hat{a}_y$. The value for current density is given by :

(A) $28 \cos x \hat{a}_z$ (B) $28 \sin x \hat{a}_y$
 (C) $28 \cos x \hat{a}_y$ (D) $28 \cos x \hat{a}_x$

5. A square coil has the dimensions $0.2 \text{ m} \times 0.2 \text{ m}$ and carrying a current of 3.0 A in a field of 10 wb/m^2 . The value of Torque is given by

(A) 10.2 N-m (B) 1.02 N-m
 (C) 0.12 N-m (D) 1.2 N-m

6. For a transmission line which is terminated in a normalised impedance Z_n , $VSWR = 2$, the value of normalised impedance is given by

(A) 2 (B) 1/2
 (C) 3 (D) 1/3

7. A displacement transducer with a shaft stroke of 3.0 cm , is applied to as shown in figure. The total resistance of the potentiometer is $5 \text{ k} \Omega$. The input voltage is 5 V , when the wiper is at 0.9 cm . The value of the output voltage is given by

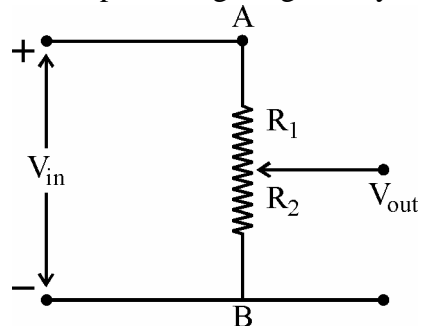

(A) 1.5 V (B) 15 V
 (C) 0.15 V (D) 5 V

8. The figure shown below, is symbol of

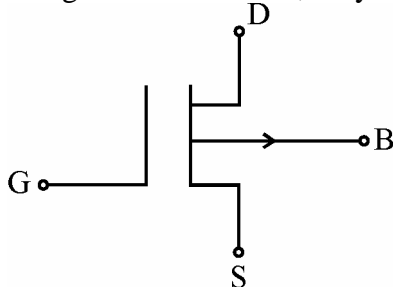

- (A) P – channel depletion MOSFET
 (B) P-channel enhancement MOSFET
 (C) Complementary MOSFET
 (D) P-channel JFET

9. Which of the following circuit comes under the class of sequential logic circuits ?

- (A) Multiplexer (B) RS Latch
 (C) Full Adder (D) ROM

10. The Hamming code for 0110 using even parity is

- (A) 0010110 (B) 1010110
 (C) 1100110 (D) 1110110

11. Phase Lock Loop (PLL) system is used for the detection of

- (A) PM (B) AM
 (C) FM (D) QAM

12. A transistor amplifier has a measured S/N of 10 at its input and 5 at its output. The transistor's Noise Figure (NF) in dB is

- (A) 2 dB (B) 3 dB
 (C) 6 dB (D) 10 dB

13. A signal varies from 20 Hz to 5 KHz is passed using pulse modulation scheme. Minimum sampling rate and number of channels that could be accommodated using TDM (assume each sample takes 10 μ s) respectively will be

- (A) 5 KHz, 5 (B) 10 KHz, 5
 (C) 5 KHz, 10 (D) 10 KHz, 10

14. The term $(1/j\omega)$ on the log-magnitude plot has a slope of

- (A) – 20 dB/decade
 (B) + 20 dB/decade
 (C) – 40 dB/decade
 (D) + 40 dB/decade

15. The Routh Array is as below :

S^6	1	8	20	6
S^5	2	12	16	
S^4	2	12	16	
S^3	0	0		

The row of zero of this ray will be replaced by coefficients of :

- (A) $S^4 + 12 S^2 + 16$
 (B) $S^3 + 3 S$
 (C) $S^4 + 6 S^2 + 8$
 (D) $S^3 + 12 S$

16. Zener breakdown mechanism occurs in reverse biased PN junction

- (A) when P and N regions are lightly doped.
 (B) when P and N regions are heavily doped.
 (C) are of silicon material only.
 (D) when P and N regions are equally doped.

17. The operation of a Photo-diode involves

- (A) Photo-conductive effect
 (B) Photo-voltaic effect
 (C) Photo-emissive effect
 (D) Photo-multiplicative effect

18. A UJT has $R_{BB} = 10$ K and $R_{B2} = 4$ K. Its intrinsic stand-off ratio is

- (A) 0.6 (B) 0.4
 (C) 2.4 (D) 3.5

19. The triggered voltage of a SCR is close to

- (A) 0.3 V
 (B) 0.7 V
 (C) 3 V
 (D) breakdown voltage

20. A thyristor can be used as
 (A) an amplifier
 (B) a resistor
 (C) a switch
 (D) a power source
21. Which of the following is an advantage to use fiber optic data transmission ?
 (A) Resistance to the data theft
 (B) Fast data transmission rate
 (C) Low noise level
 (D) All of the above
22. A breakdown which is caused by cumulative multiplication of carriers through field induced impact ionization occurs in
 (A) Avalanche diode
 (B) Tunnel diode
 (C) Varactor diode
 (D) Gunn diode
23. Transfer function of a system is necessary for the calculation of
 (A) the time constant
 (B) the output for a given input
 (C) the steady state gain
 (D) the order of the system
24. If one or more pairs of simple roots are located on imaginary axis of the s-plane but there are no roots in the right half of s-plane, the response due to initial condition will
 (A) decrease to zero as time approaches infinity.
 (B) increase as time approaches infinity.
 (C) be undamped sinusoidal oscillations.
 (D) be damped unsinusoidal oscillation and the damping factor will depend upon the relative location of the roots on the imaginary axis.
25. 8255A Programmable Peripheral Interface IC has got the 24 I/O lines in the following way (General form) :
 (A) Port A with 8 input lines, Port B with 8 output lines, Port C (upper nibble) with 4 input lines and Port C (lower nibble) with 4 output lines.
 (B) Port A with 8 input/output lines, Port B with 8 input lines and Port C with 8 output lines.
 (C) Port A with 8 input lines, Port B with 8 output lines and Port C with 8 bits as either input or output lines.
 (D) Port A with 8 lines as input/output lines, Port B with 8 lines as input/output lines, Port C (lower nibble) with 4 lines as input/output lines. Port C (upper nibble) with 4 lines as input/output lines.
26. C program is as follows : The result of the program is

```

int i; /*...declare integer i...*/
i=10; /*...set i to 10 ...*/
i=i+'A'; /*...add character A...*/
/*...to integer i...*/
print f ("i=%d", i);

```

 (A) 55 (B) 51
 (C) 71 (D) 75
27. Consider the following conditional expression

$$z = (x > y) ? x : y;$$
 if $x = 2$ and $y = 8$, the value of z is
 (A) 2 (B) 8
 (C) 6 (D) 10

28. `int Net = 0;`
`if (x < 50`
`if (y > 5)`
`Net = x + y;`
`else`
`Net = x - y;`
For this C program segment, $x = 55$ and $y = 5$, then the value Net is
(A) 0 (B) 60
(C) 50 (D) 55

29. In 8253 programmable interval timer, in which modes, the counting is neither enabled nor disabled ?
(A) 0 and 4 (B) 1 and 5
(C) 1 and 4 (D) 3 and 5

30. In which mode of 8259A programmable interrupt controller, all the Interrupt Requests (IRs) are arranged from highest to lowest with IR_0 as the highest and IR_7 as the lowest ?
(A) Fully Nested Mode
(B) Automatic Rotation Mode
(C) Specific Rotation Mode
(D) Simple Rotation Mode

31. A transmission line has following characteristics :

1. $Z_L = \frac{V_f + V_r}{I_f + I_r}$

2. $Z_L = \frac{V_f - V_r}{I_f - I_r}$

3. γ (propagation constant) = $\sqrt{(R + j\omega L)(G + j\omega C)}$

4. γ propagation constant) = $\sqrt{\frac{(R + j\omega L)}{(G + j\omega C)}}$

Which of the following is correct option ?

- (A) 1 and 4 is correct.
(B) 2 and 3 is correct.
(C) 1 and 3 is correct.
(D) 2 and 4 is correct.

32. In an OPAMP, following characteristics are given :

1. PSRR (Power Supply Rejection Ratio) = 0
2. Thermal Drift is defined in terms of μ Amperes/ $^{\circ}$ C.
3. Thermal drift is defined in terms of μ V/ $^{\circ}$ C.
4. Slew rate is defined in terms of V/ μ s.

Which one of the following is correct ?

- (A) 1 and 2 only
(B) 1 and 3 only
(C) 1, 3 and 4
(D) 1, 2 and 4

33. Consider the following statement :

- (i) A flip-flop is used to store 1-bit of information.
- (ii) Race-around condition occurs in J-K flip-flop when both the inputs are 1.
- (iii) Master-slave configuration is used in flip-flop to store 2-bits of information.
- (iv) A transparent latch consists of D type flip-flop.

Which of the following statements is/are true ?

- (A) (i) only
(B) (i), (iii) and (iv)
(C) (i), (ii) and (iv)
(D) (ii) and (iii) only

34. An AM demodulator can be implemented with

- (i) A linear multiplier followed by a low pass filter.
- (ii) A linear multiplier followed by a high-pass filter.
- (iii) A diode followed by low pass filter.
- (iv) A linear multiplier followed by band-stop filter.

The correct answer is :

- (A) (i) only (B) (iii) only
(C) (i) and (iii) (D) (iv) only

35. In feedback control system, relative stability can be calculated using

- (i) Routh-Hurwitz Array
- (ii) Nyquist plot
- (iii) Polar plot
- (iv) Root Locus Techniques

Correct answer is

- (A) All of the above
- (B) (i) and (ii) only
- (C) (ii) and (iv) only
- (D) (ii), (iii) and (iv)

36. In comparison to LED, LASER has

1. High emission frequency.
2. No tuning arrangement.
3. Wide spectral bandwidth.
4. Provision for confinement.

Of these statements :

- (A) 1, 2 & 4 are correct.
- (B) 1, 2, & 3 are correct.
- (C) 1 & 4 are correct.
- (D) 2 & 3 are correct.

37. The turn-off time of an SCR can be reduced by

1. Quick withdrawal of the gate voltage.
2. Reducing life-time by doping with gold.
3. Applying a negative voltage pulse to the gate.

Of these statements :

- (A) 1, 2 and 3 are correct.
- (B) 1 and 2 are correct.
- (C) 1 and 3 are correct.
- (D) 2 and 3 are correct.

38. Consider the following statements regarding a semiconductor :

1. Acceptor level lies close to the valence band.
2. Donor level lies close to the valence band.
3. n-type semiconductor behaves as a conductor at zero Kelvin.
4. p-type semiconductor behaves as an insulator at zero Kelvin.

Of these statements :

- (A) 2 and 3 are correct.
- (B) 1 and 3 are correct.
- (C) 1 and 4 are correct.
- (D) 3 and 4 are correct

39. Transfer function for a control system is defined for where

- (i) linear system
- (ii) nonlinear system
- (iii) time invariant system
- (iv) time variant system

- (A) (i) and (iii) (B) (ii) and (iv)
- (C) (i) and (iv) (D) (ii) and (iii)

40. Tri state Buffers provide

- (i) reduction of current consumption in the circuit.
- (ii) isolation from input to output.
- (iii) high impedance during OFF state.
- (iv) low impedance during ON state.

- (A) (i) and (iv) (B) (ii) and (iv)
- (C) (i) and (ii) (D) (i) and (iii)

41. Consider the following :

1. CE stage 2. CC stage
3. OP amp 4. CB stage

The correct sequence of the input impedance in increasing order is :

- (A) 4, 1, 2, 3 (B) 1, 4, 2, 3
- (C) 1, 2, 4, 3 (D) 4, 2, 1, 3

42. The various components in super heterodyne receiver is arranged as

- (i) AM Detector (ii) Mixer
- (iii) RF Amplifier (iv) AF Amplifier

The correct sequence is

- (A) (iii), (ii), (i), (iv)
- (B) (i), (ii), (iv), (iii)
- (C) (iii), (ii), (iv), (i)
- (D) (ii), (i), (iii), (iv)

43. For a unity feedback control system having an open-loop transfer function

$$G(S) = \frac{K(S + 2)}{S^2(S^4 + 7S + 12)}$$

The error constant K_p , K_v and K_a respectively are

- (A) $\infty, \infty, K/6$ (B) $0, 0, K/6$
- (C) $\infty, 0, K/6$ (D) $0, \infty, K/6$

44. Arrange in ascending order the following logic families based on power delay products

(i) ECL (ii) TTL (iii) CMOS

Codes :

(A) (ii), (iii), (i) (B) (ii), (i), (iii)

(C) (i), (ii), (iii) (D) (iii), (ii), (i)

45. Consider the following four common type of transistors :

1. Point Contact Transistor
2. Bipolar Junction Transistor
3. MOS Field Effect Transistor
4. Junction Field Effect Transistor

Correct arrangement of these transistors in the increasing order of input impedance is

(A) 1, 2, 4, 3 (B) 1, 2, 3, 4

(C) 2, 1, 3, 4 (D) 2, 1, 4, 3

46. If the various logic families are arranged in the ascending order of their fan-out capabilities, the sequence will be

(A) TTL, DTL, ECL, MOS

(B) DTL, TTL, MOS, ECL

(C) MOS, DTL, TTL, ECL

(D) ECL, TTL, DTL, MOS

47. Consider the following waves/rays :

1. UV Rays
2. X Rays
3. Visible light
4. UHF waves

The correct sequence of the descending order in terms of frequency is :

(A) 3, 1, 2, 4 (B) 4, 3, 1, 2

(C) 2, 1, 3, 4 (D) 2, 4, 1, 3

48. The structure of a decision table, divided into four parts like

1	4
2	3

(i) Condition Stub

(ii) Condition Entries

(iii) Action Stub

(iv) Action Entries

(A) (i), (ii), (iv) and (iii)

(B) (ii), (iv), (iii) and (i)

(C) (i), (iii), (iv) and (ii)

(D) (i), (iv), (ii) and (iii)

49. The parameters associated with time response of control system are

(i) Delay time (t_d)

(ii) Settling time (t_s)

(iii) Rise time (t_r)

(iv) Peak time (t_p)

Arrange the above in the order, the parameter which is having minimum time to the parameter which has got the maximum time.

(A) (i), (iv), (ii) and (iii)

(B) (i), (iii), (ii) and (iv)

(C) (i), (iv), (iii) and (ii)

(D) (i), (iii), (iv) and (ii)

50. In the Assembly program, the following steps are to be followed. Find the sequence in which the program to be written for 8085 microprocessor.

(i) Initialization of variables.

(ii) Initialization of stack.

(iii) Enable or disable interrupts.

(iv) Program should be completed with last line as 'END' statement.

(A) (i), (iii), (ii) and (iv)

(B) (i), (ii), (iii) and (iv)

(C) (ii), (i), (iii) and (iv)

(D) (ii), (iii), (i) and (iv)

51. Match the following lists :

List - I

List - II

(a) Alpha of Transistor

(i) > 1

(b) Beta of Transistor

(ii) ∞

(c) CMRR (Common Mode Rejection Ratio)

(iii) < 1

(d) PSRR (Power Supply Rejection Ratio)

(iv) 0

The correct match is :

(a) (b) (c) (d)

(A) (iii) (i) (ii) (iv)

(B) (iv) (i) (ii) (iii)

(C) (i) (ii) (iii) (iv)

(D) (ii) (i) (iii) (iv)

52. Match the following lists :

- | List – I | List - II |
|----------------|----------------------------|
| (a) Magnetron | (i) Detector |
| (b) Pin diode | (ii) Bunching |
| (c) Klystron | (iii) Low Power Oscillator |
| (d) Gunn diode | (iv) π -mode |

The correct match is :

- | | | | |
|-----------|-------|-------|-------|
| (a) | (b) | (c) | (d) |
| (A) (ii) | (iii) | (iv) | (i) |
| (B) (i) | (ii) | (iii) | (iv) |
| (C) (iii) | (i) | (ii) | (iv) |
| (D) (iv) | (i) | (ii) | (iii) |

53. Match the following lists :

- | List – I | List - II |
|-----------------------|---|
| (a) Compadding | (i) Improving image rejection |
| (b) Squelch | (ii) Variation of step rise in quantisation |
| (c) Pre-emphasis | (iii) Muting the receiver |
| (d) Double conversion | (iv) Boosting of higher modulating frequencies at the transmitter |

Codes :

- | | | | |
|----------|-------|-------|-------|
| (a) | (b) | (c) | (d) |
| (A) (ii) | (iii) | (iv) | (i) |
| (B) (ii) | (i) | (iv) | (iii) |
| (C) (i) | (ii) | (iii) | (iv) |
| (D) (i) | (ii) | (iv) | (iii) |

54. Match the following lists :

- | List – I | List - II |
|-----------|-----------------------------|
| (a) 74150 | (i) Quad 2 : 1 Multiplexer |
| (b) 74152 | (ii) Dual 4 : 1 Multiplexer |
| (c) 74153 | (iii) 8 : 1 Multiplexer |
| (d) 74157 | (iv) 16 : 1 Multiplexer |

Codes :

- | | | | |
|----------|-------|-------|-------|
| (a) | (b) | (c) | (d) |
| (A) (i) | (ii) | (iii) | (iv) |
| (B) (iv) | (iii) | (ii) | (i) |
| (C) (iv) | (ii) | (iii) | (i) |
| (D) (ii) | (i) | (iv) | (iii) |

55. Match the following lists :

- | List – I
(Characteristic of the device) | List - II
(Device) |
|--|-----------------------|
|--|-----------------------|

- | | |
|-----------------------------------|-------------|
| (a) Voltage controlled device | (i) BJT |
| (b) Current controlled device | (ii) UJT |
| (c) Conductivity modulated device | (iii) FET |
| (d) Negative conductance device | (iv) IMPATT |

Codes :

- | | | | |
|-----------|-------|------|------|
| (a) | (b) | (c) | (d) |
| (A) (ii) | (iii) | (i) | (iv) |
| (B) (ii) | (iii) | (iv) | (i) |
| (C) (iii) | (i) | (iv) | (ii) |
| (D) (iii) | (i) | (ii) | (iv) |

56. Match the following lists :

- | List – I | List - II |
|---------------------------------|---|
| (a) Optical fiber communication | (i) FDM |
| (b) Mobile communication | (ii) TDM |
| (c) Digital communication | (iii) CDMA |
| (d) Analog communication | (iv) Wavelength-Division Multiplexing (WDM) |

Codes :

- | | | | |
|-----------|-------|------|-------|
| (a) | (b) | (c) | (d) |
| (A) (i) | (iii) | (ii) | (iv) |
| (B) (iv) | (iii) | (ii) | (i) |
| (C) (ii) | (iv) | (i) | (iii) |
| (D) (iii) | (i) | (ii) | (iii) |

57. (a) Bode's-Plot representation (i) not a frequency domain technique.
 (b) Nyquist Diagram (ii) low frequency and high frequency characteristics of the transfer function can be determined
 (c) Nichols Charts (iii) decides the Stability criteria
 (d) Root-locus Method (iv) also known as Polar plots

Codes :

- (a) (b) (c) (d)
 (A) (iv) (iii) (i) (ii)
 (B) (iv) (iii) (ii) (i)
 (C) (iii) (iv) (i) (ii)
 (D) (ii) (iii) (iv) (i)

58. The following are features of a micro controller 8051 :

- (i) 4 k bytes of ROM or EPROM
 (ii) 128 k bytes of data memory
 (iii) Four programmable I/O ports
 (iv) Three 16 bit timer/event counters.

- (A) (i), (ii) and (iii)
 (B) (i), (ii) and (iv)
 (C) (i), (iii) and (iv)
 (D) (ii), (iii) and (iv)

59. Identify the peripheral devices for their applications.

- (a) 8155 (i) Serial Communication
 (b) 8279 (ii) Timers and Counters
 (c) 8253 (iii) Keyboard and display interface
 (d) 8251 (iv) Additional input/output lines to processor

Codes :

- (a) (b) (c) (d)
 (A) (ii) (iii) (iv) (i)
 (B) (iii) (iv) (i) (ii)
 (C) (iv) (i) (ii) (iii)
 (D) (iv) (iii) (ii) (i)

60. Match the following lists :

List - I

List - II

- | | | | |
|---|-------------------------------|----|---|
| a | Stability of Control System | 1. | Oscillation in which the amplitude decreases with time. |
| b | Unstability of Control System | 2. | All roots of characteristic equation have negative real part. |
| c | Frequency response | 3. | Steady state response |
| d | Damped Oscillation | 4. | Any root of characteristic equation has a positive real part |

Codes :

- | | | | | |
|-----|---|---|---|---|
| | a | b | c | d |
| (A) | 4 | 2 | 3 | 1 |
| (B) | 2 | 4 | 3 | 1 |
| (C) | 2 | 4 | 1 | 3 |
| (D) | 4 | 2 | 1 | 3 |

Directions : Q. Nos. 61 to 70, the following items consist of two statements, one labelled the "Assertion (A)" and the other labelled the "Reason (R)". You are to examine these two statements carefully and decide if the Assertion (A) and the Reason (R) are individually true and if so, whether the Reason (R) is a correct explanation of the Assertion (A). Select your answers to these items using the codes given below and mark your answer accordingly.

Codes :

- (A) Both (A) and (R) are correct and (R) is correct explanation of (A).
 (B) Both (A) and (R) are correct, but (R) is not correct explanation of (A).
 (C) (A) is true, but (R) is false.
 (D) (A) is false, but (R) is true.

61. **Assertion (A)** : In amplifiers, it is easy to compare two powers on a Logarithmic rather than on linear scale. It is called decibel.
Reason (R) : Decibel is defined as $N = 10 \log \frac{P_2}{P_1}$, where P_2 is output power and P_1 is input power.
62. **Assertion (A)** : Magnetron are not cross field devices.
Reason (R) : They make use of electric and magnetic fields simultaneously. The fields are perpendicular to each other.
63. **Assertion (A)** : TDM can be employed to transmit channels having unequal bandwidths.
Reason (R) : If sampling theorem is strictly followed, any analog signal can be reconstructed back from the samples.
64. **Assertion (A)** : A NAND gate is called a Universal logic element.
Reason (R) : Any logic function can be realized using NAND gates alone.
65. **Assertion (A)** : The stability of a control system can be determined from the location of roots of characteristic equation.
Reason (R) : For stability the roots should lie on the left half of s-plane.
66. **Assertion (A)** : The intrinsic Fermi level of a semiconductor does not lie exactly at the middle of the energy band gap.
Reason (R) : The densities of the available states in valence and conduction bands of an intrinsic semiconductor are equal.

67. **Assertion (A)** : The operating principle of Laser is based on stimulated emission process.
Reason (R) : In coherent radiation, the emitted photons have same phase, same polarization and same direction with the incident photon.
68. **Assertion (A)** : A microprocessor interfaced with inputs, outputs and other peripheral devices is also called a micro controller system and is capable of controlling the process.
Reason (R) : The microprocessor is a device which processes the instructions.
69. **Assertion (A)** : In control system design, the transfer function consists of both poles and zeros. To make the system stable, the poles plotted in Bode plot should be near to origin.
Reason (R) : The zeros must be also near to origin.
70. **Assertion (A)** : A p-channel enhancement MOSFET based transistor can be turn on prematurely.
Reason (R) : Most contaminants in MOS fabrication are mobile positively charged ions and they get trapped between the gate and the substrate in a n-channel enhancement MOSFET, whereas they are trapped on the other side of the substrate in the case of a p-channel enhancement MOSFET.

Read the paragraph and answer the Question Nos. 71 to 75.

The field effect transistor is a semiconductor device which depends for its operation on the control of current by an electric field. There are two types of field effect transistor, the Junction Field Effect Transistor (JFET) and Metal-Oxide-Semiconductor (MOSFET) FETs operation depends upon the flow of majority carriers only. It is therefore a unipolar device. BJT is a bipolar device. FET is relatively immune to radiation and it exhibits a high input resistance typically many mega-ohms. It is less noisy than a tube or a bipolar transistor. It exhibits no offset voltage at zero drain current, and hence makes an excellent signal chopper. FETs are more temperature stable than BJTs. JFET is three terminal device with gate applied potential control the flow of charges from source to drain. The n-channel MOSFET consists of a lightly p-type substrate into which two highly doped n^+ regions are diffused. These n^+ sections, which will act as the source and drain. A thin layer of insulating SiO_2 is grown over the surface of the structure and holes are cut into the oxide layer, allowing contact with the source and drain. This layer results in an extremely high input resistance.

71. The point above the drain voltage, where there is no increase in drain current in a JFET is called as
 (A) Break down point
 (B) Pinch off point
 (C) Knee point
 (D) Critical point
72. FET is disadvantageous in comparison with BJT because of
 (A) High input impedance
 (B) Low noise
 (C) High gain bandwidth behaviour
 (D) Current controlled behaviour
73. For an n-channel silicon FET with $\alpha = 3 \times 10^{-4}$ cms and $N_D = 10^{15}$ electron/cm³, find the pinch is of voltage.

$$\left[\epsilon = 12\epsilon_0 \frac{1}{4\pi\epsilon_0} = 9 \times 10^9 \frac{\text{Newton} - \text{m}^2}{\text{Coulomb}} \right]$$

 (A) 6.00 V (B) 5.4 V
 (C) 6.8 V (D) 4.5 V
74. An FET is a better chopper than BJT because it has
 (A) higher series on resistance
 (B) lower input current
 (C) higher input impedance
 (D) lower off-set voltage
75. For an n-channel enhancement mode MOSFET the drain current
 (A) decreases with increase in drain current.
 (B) decreases with decreases in drain voltage.
 (C) increases with increase in drain voltage.
 (D) increases with decrease in gate voltage.

Space For Rough Work